

Quick Start Guide

General Information

- All guidance in the following document should follow the recommendations of BS 5839-6 and BS EN 50292:2023
- Espire Alarm accessories have been designed and developed for fixed residential installation and use.
- The Alarm accessory is required to be installed into compatible Espire alarms only
- Before commencing electrical work, ensure the mains isolator on the consumer unit is in the 'OFF' position to prevent electric shock.
- After installation the Alarm Accessory is to be tested weekly.
- If it is a hybrid system ~ only one alarm on the hardwired interlinked section is to have an RF-LINK module installed with the IC conductor connected.

Product Description

ES1RF Espire Alarm RF Module for Mains Powered Alarms with Lithium Battery Backup

For use with Espire alarms with Lithium battery backup to use the RF-Link feature

For use with Espire alarm models: ES1SLV, ES1HLV, ES1MULV, ES1CLV, ES1CHLV

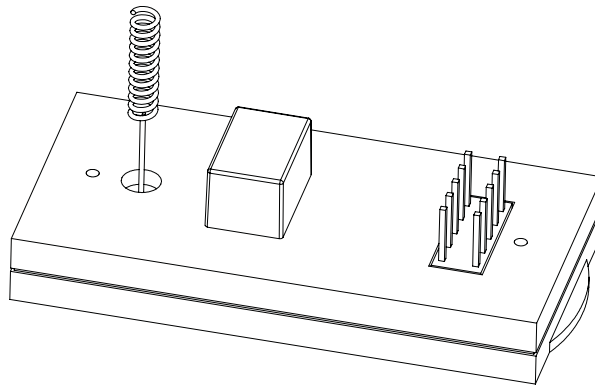

Product Description

ES1RF2 Espire Alarm RF Module for Lithium Battery Powered Alarms

For use with Espire alarms with Lithium battery backup to use the RF-Link feature

For use with Espire alarm models: ES1SL, ES1HL, ES1MUL, ES1CHL, ES1CL

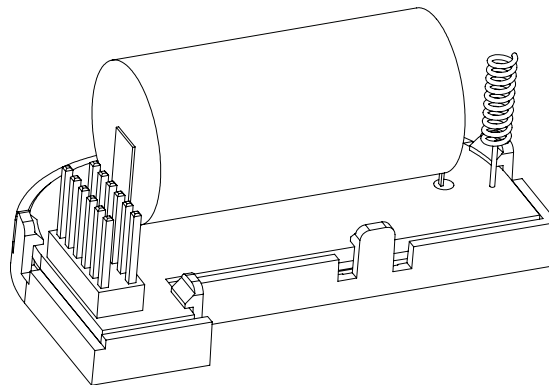

RF-Link module installation

Removing the alarm from its Lock-in base

Isolate the mains power supply prior to the removal of the Alarm

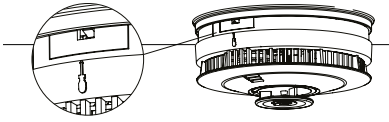

Step 1.
Locate the screwdriver symbol on the side of the Alarm.

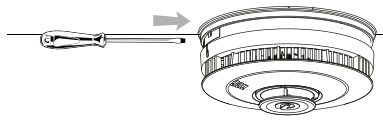

Step 2.
Insert a flathead screwdriver or the Espire Multi-tool (ES1MTW/B) horizontally into the centre of the release lever.

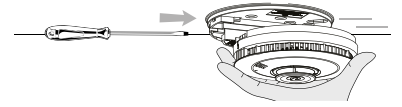

Step 3.
With the screwdriver in place, push away the lower half of the alarm from the screwdriver

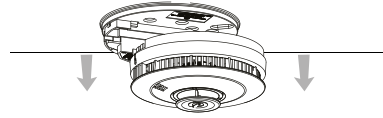

Step 4.
Hold the lower half of the Alarm, and slide to remove from the lock-in base.

Installing the RF-Link module



Step 1.
Locate the modules installation location on the underside of the desired alarm

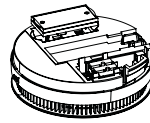

Step 2.
Align the antennae to the antennae hole, and the pins' socket

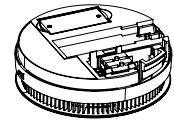

Step 3.
Carefully insert the module into the module socket, ensuring that the module is completely flush with the alarm.

Uninstalling the RF-Link module



Step 1.
Locate the modules removal wings on the side of the modules housing

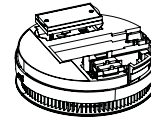

Step 2.
Carefully pull the module out, and ensure to pull it out as straight as possible not damage the pins

RF-Link Introduction

Up to 28 Alarms can be interconnected wirelessly via the RF-Link function .The RF-Link module is optional, ensure the correct model has been supplied. Prior to RF Coding, ensure that all system Alarms are correctly wired, powered and functioning independently.

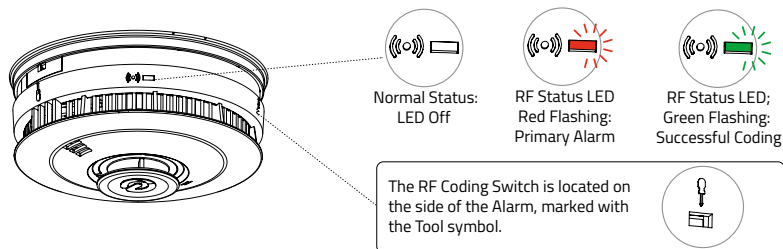

RF-Link Coding

The first Alarm that enters RF Coding Mode will be assigned as the 'PRIMARY', all other Alarms will be assigned as a 'SECONDARY'. It is important to mark the PRIMARY Alarm with the label provided for future servicing of the system.

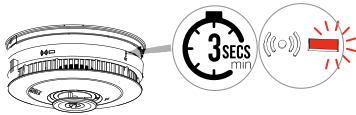

Step 1.

Using the supplied pairing tool press and hold the RF Coding Button on one of the system's Alarms for a minimum of 3 seconds and release when the RF Status LED flashes Red.



Step 2.

While the PRIMARY Alarm is in coding mode, at the next Alarm press the RF Coding Button 3 times and the RF Status LED will turn Green to confirm successful coding. Repeat the process on the remaining Alarms.

Note: RF Coding Mode will be active for 30 minutes before auto time out.

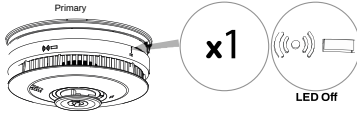

Step 3.

Once all the Alarms have been coded to the PRIMARY Alarm, return to the PRIMARY Alarm and single press the RF Coding Button and the RF Status LED will stop flashing. RF Coding Mode has now ended.

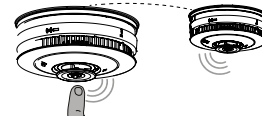

Step 4.

After coding is completed, test each individual Alarm and check that all interconnected Alarms sound the horn.

Note: There may be up to a 10 second delay for the coded Alarms to respond after pressing the Test/Hush button.

Deleting an RF-Link Coded Alarm

Press and hold the RF Coding Button for 3 seconds and release when the RF Coding Status LED flashes Red. Single press the RF Coding Button to confirm deletion, the RF Status LED will stop flashing.

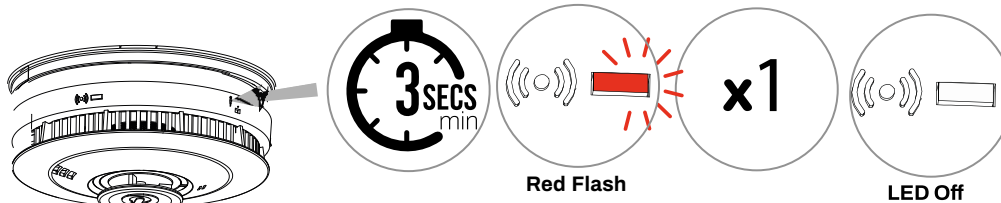

Important: If the PRIMARY Alarm is deleted, the system will require re-coding.

Resetting an RF-Link Coded Alarm

When configuring a new or existing system it may be required to reset all the Alarms. Resetting a complete system can help to resolve issues encountered. Deleting a device will reset the coding of an Espire alarm.

Hybrid System

A hybrid system is a system that uses both hardwired interconnected alarms, as well as RF-Link interconnected alarms.

Up to 28 alarms can be interconnected, this is inclusive of both hardwired & RF-link devices.

To achieve this, at least one of the hardwired alarms will require an ES1RF to connect to the hardwired interconnected alarms.

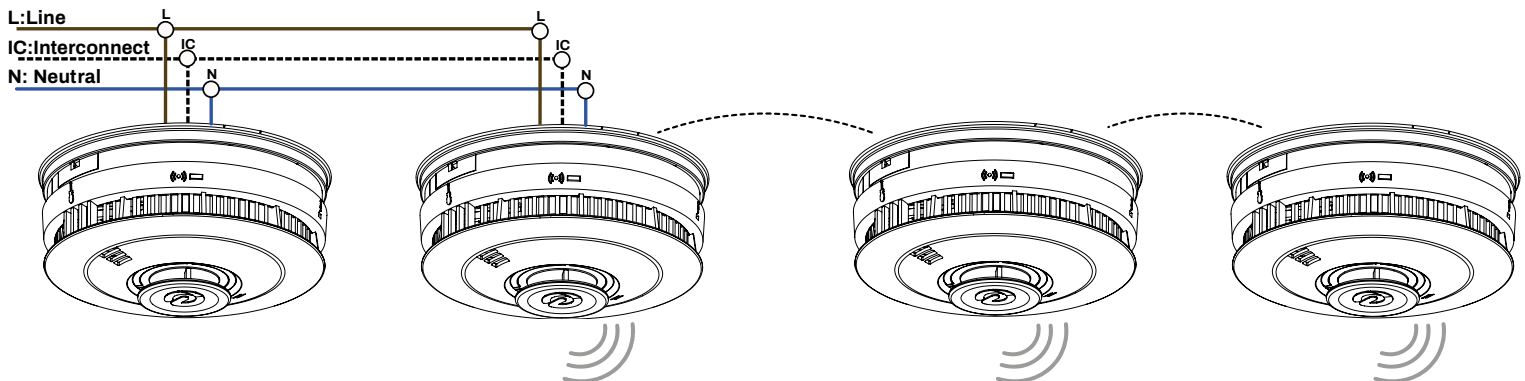

RF Remote Control System;

These are systems that utilise the Espire Remote Control, consult the Remote Control manual (ES1REM), for limitations and further guidance.

For additional product and installation instructions scan the applicable QR code



UK



ROI



When disposing of this product, it must be recycled in accordance to the Waste Electrical & Electronic Equipment (WEEE) regulations.